

# KW5

## 1/2 HP Sewage Pump

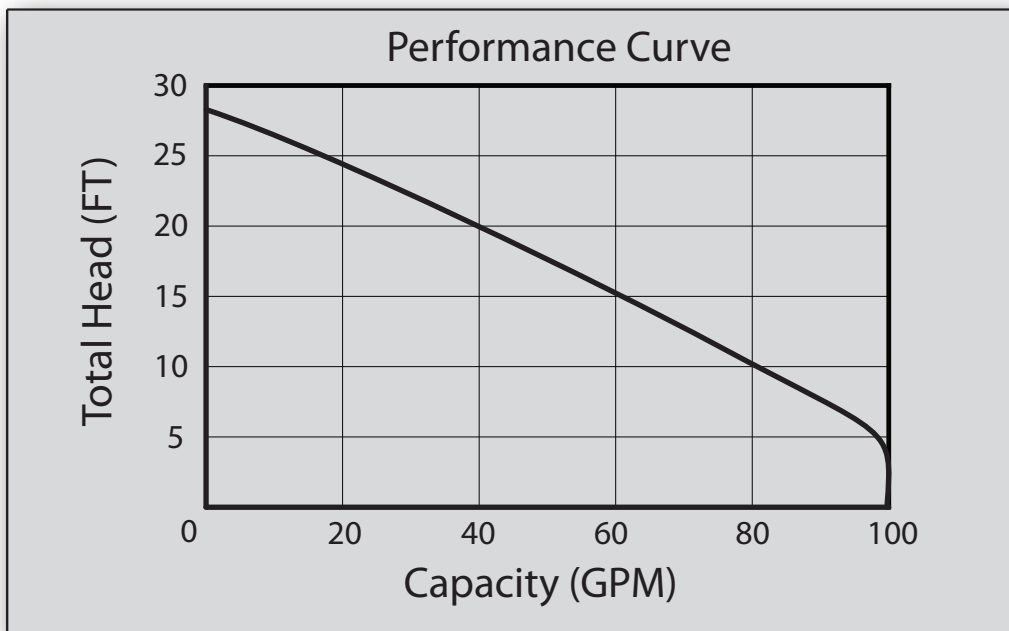

- 2" Solids-Handling
- Heavy-Duty Mechanical Seal
- Recessed, Clog-Free Impeller
- Durable, All Cast Iron Construction
- Dependable Operation
- Automatic and Manual Models
  - KW5A (Automatic w/ Piggyback Float Switch)
  - KW5M (Manual)



# KW5 Features and Benefits

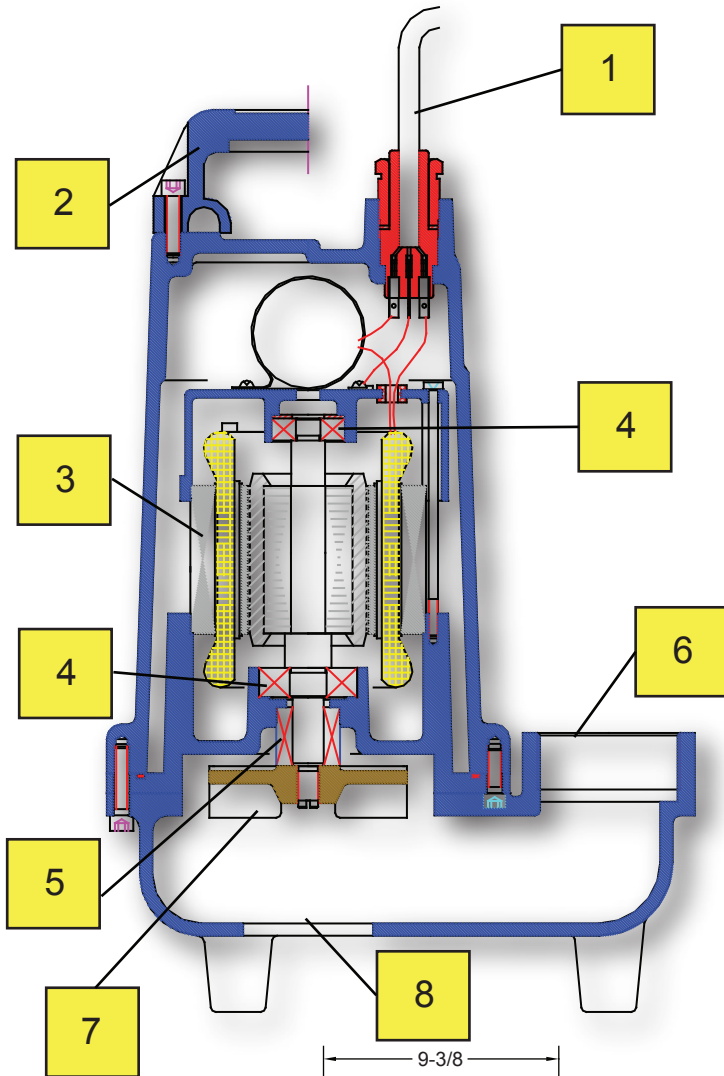

1. **Power Cord** - 20 ft w/ Plug, UL & CUL, 16 AWG, Type SJTOW.
2. **Castings** - Class 30 ASTM A48, Cast Iron.
3. **Motor** -1/2HP, 115 Volt, 10 Amp, 3450 RPM, Oil-Filled, Class B, 60 Hz
4. **Bearings** - Upper and Lower Ball, Oil-Lubricated.
5. **Shaft Seal** - Silicon Carbide.
6. **Discharge** - 2" NPT Vertical.
7. **Impeller** - Cast Iron.
8. **Solids-Handling** - Up to 2" Dia.
9. \*Optional Piggy-Back Float.

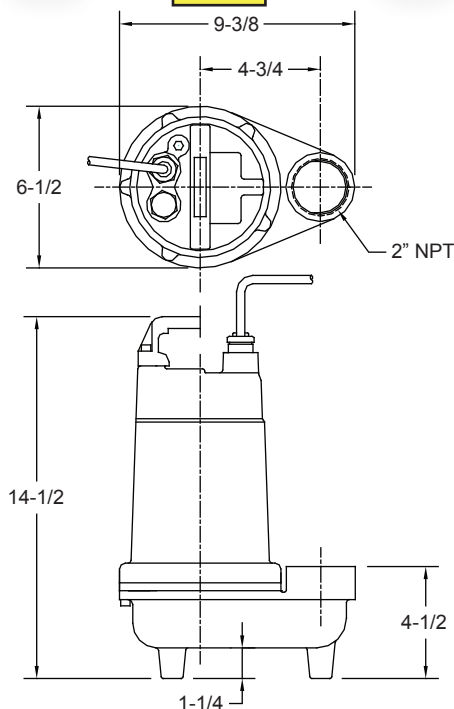

471E State Route 250 East · Ashland, Ohio 44805  
 419.207.9400 fax 419.207.8031  
[www.keenpump.com](http://www.keenpump.com)

# *KW5 Specifications*

**Pump Model** – Pump shall be of the submersible centrifugal type, 1/2 HP KEEN KW5 Series. The pump shall easily pass 2” diameter solids through the pump end without jamming and exit through the 2” NPT discharge.

**Operating Conditions** – The pump shall have a capacity of \_\_\_\_\_ GPM at a total head of \_\_\_\_\_ feet, and shall use a motor rated at 1/2 HP and 3450 RPM.

**Pump Impeller** – Cast iron and threaded on a stainless steel shaft extension. The impeller shall be of the recessed vortex type to provide an unobstructed passage through the volute for the solids.

**Pump Housing Construction** – All components of the pump construction (cord cap, motor housing, seal plate, volute) shall be cast iron, ASTM A-48, Class 30. There shall not be any composite materials used for any pump components.

**Mechanical Seal** – The motor shall be protected by a mechanical, Type 21, (silicon carbide) shaft seal. The mechanical seal face shall be lapped to a flatness of one light band. All hardware shall be stainless steel. The elastomer materials shall be nitrile.

**Motor** – The pump motor shall be of the submersible type, rated 1/2 HP, 3450 RPM. The motor shall be for 60 Hz, 115 volt, single phase operation. The motor shall be of the permanent split capacitor design with an internal start capacitor for high starting torque. Motor operating temperature must not exceed Class B ratings.

The stator winding shall be of the open type with Class B insulation. Winding housing shall be filled with a clean, high dielectric oil that lubricates bearings and seals, transferring heat from windings and rotor to the outer cast housing. Air-filled motors which do not have the superior heat dissipating capabilities of oil-filled motors shall not be considered equal.

The motor shall have two heavy duty ball bearings to support the pump shaft, taking radial and thrust loadings. Ball bearings shall be designed for a minimum 50,000 hours B-10 life. The shaft shall be stainless steel, threaded at the impeller.

The motor shall be capable of operating over the full range of the performance curve without overloading. Single phase motors shall have a heat sensor thermostat and overload attached to the top end of the motor windings to stop the motor if the motor winding temperature reaches 200 degrees F. The high temperature shut-off will cause the pump to cease operation, should a control failure cause the pump to run in a dry wet well. The thermostat shall automatically reset when the motor cools to a safe operating temperature.

**Power Cord** – The motor power cord shall be 16 AWG SJTOW, 20’ length. The cable jacket shall be sealed at the motor entrance by means of a rubber compression washer with concentric ribbing. A compression fitting shall securely hold the cable jacket and compression grommet in place.



471E State Route 250 East · Ashland, Ohio 44805  
419.207.9400 fax 419.207.8031  
www.keenpump.com