

Pump Series	K14VK	14" SUBMERSIBLE SEWAGE PUMPS
DIMENSIONAL DATA		

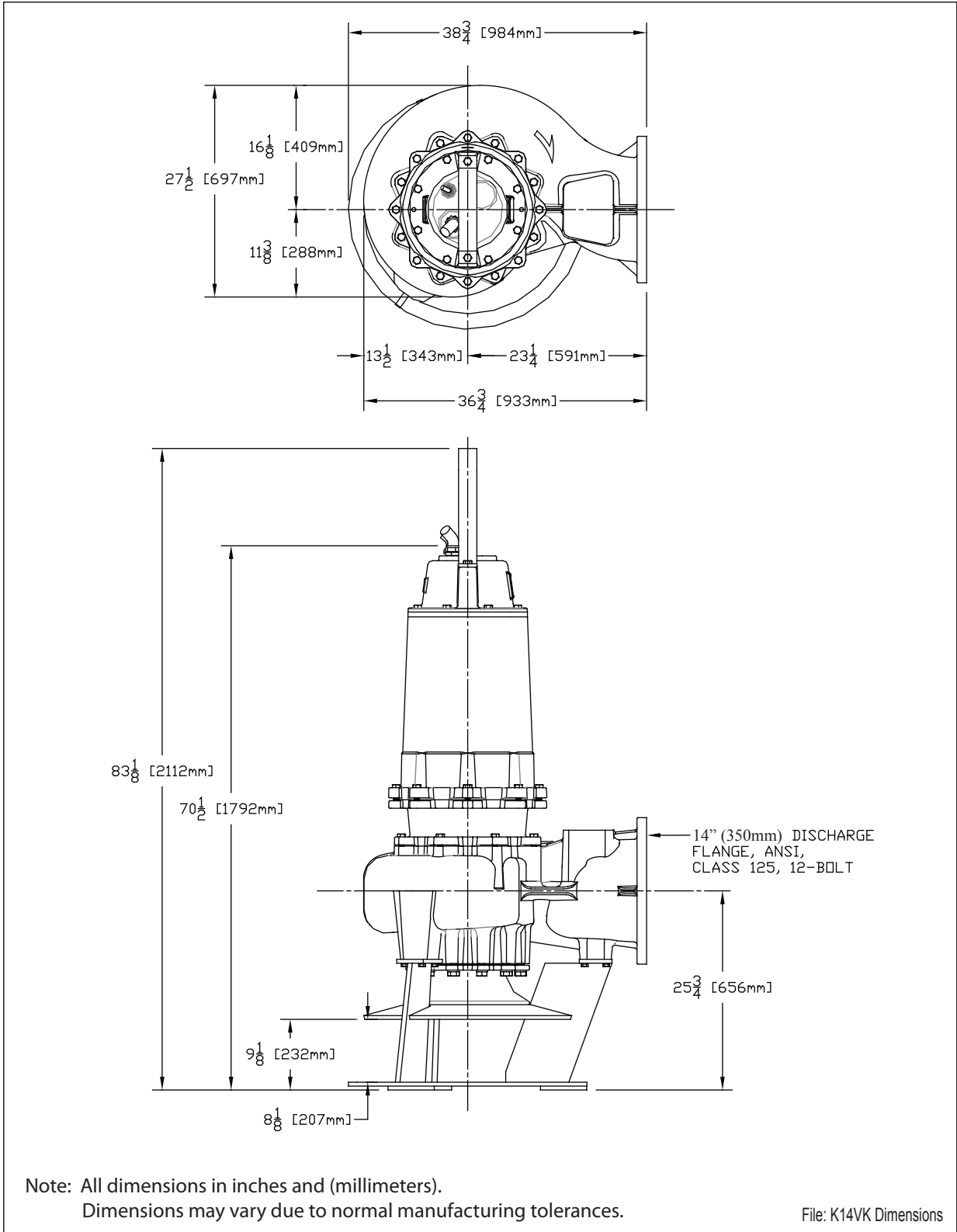

Pump Series

K14VK

14" SUBMERSIBLE SEWAGE PUMPS

LIFTOUT DIMENSIONAL DATA

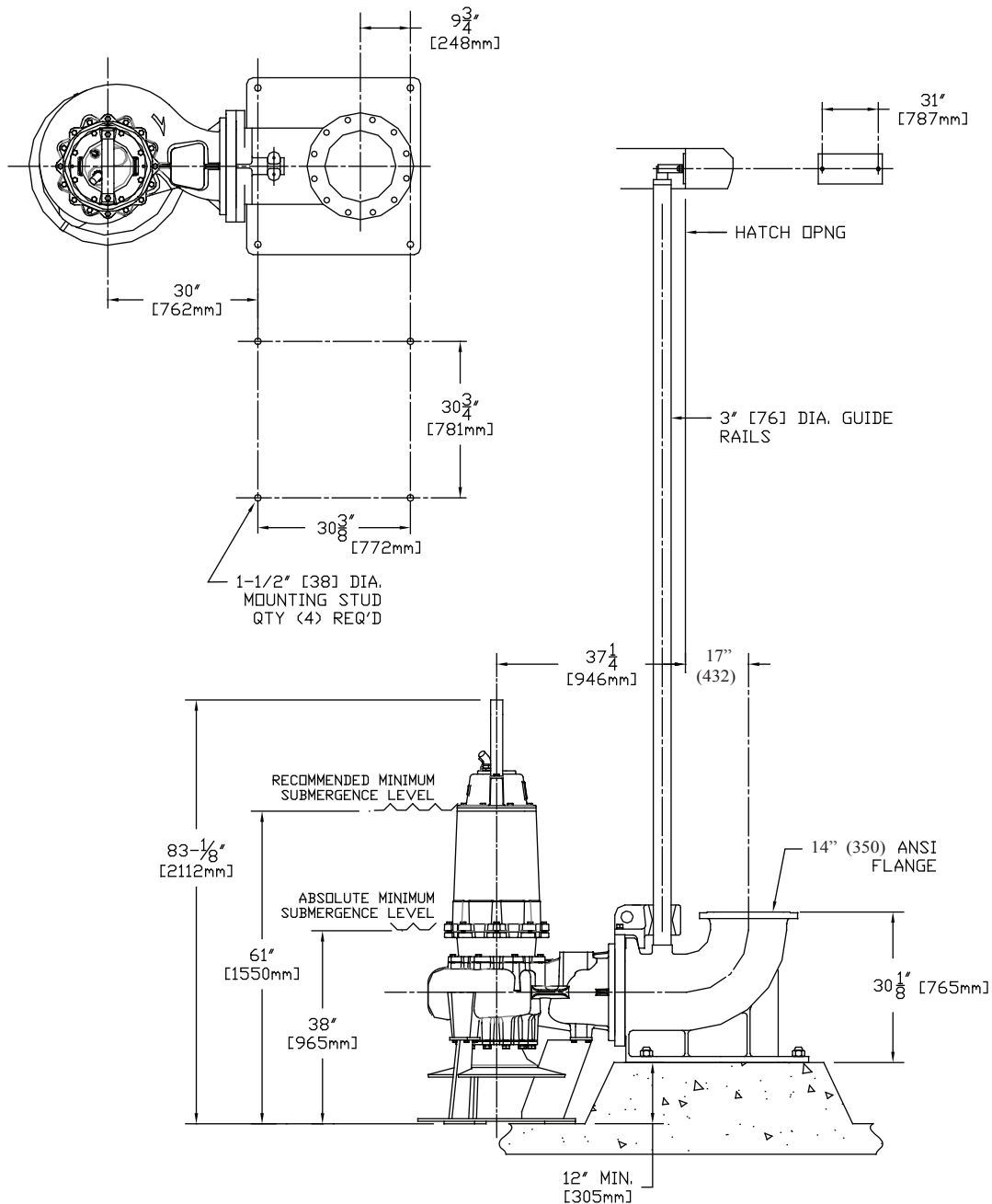
Notes:

1. All dimensions in inches and (millimeters).
2. Discharge flange ANSI Class 125 unless noted.
3. Absolute minimum and recommended minimum submergence levels noted.
4. Discharge base elbow must be placed above sump bottom as noted.
5. Dimensions may vary due to normal manufacturing tolerances.
6. If discharge pipe is larger than discharge elbow, eccentric reducer must be used limited to 2X larger maximum.

Pump Series	K14VK	14" SUBMERSIBLE SEWAGE PUMPS
SIMPLEX INSTALLATION DIMENSIONAL DATA		

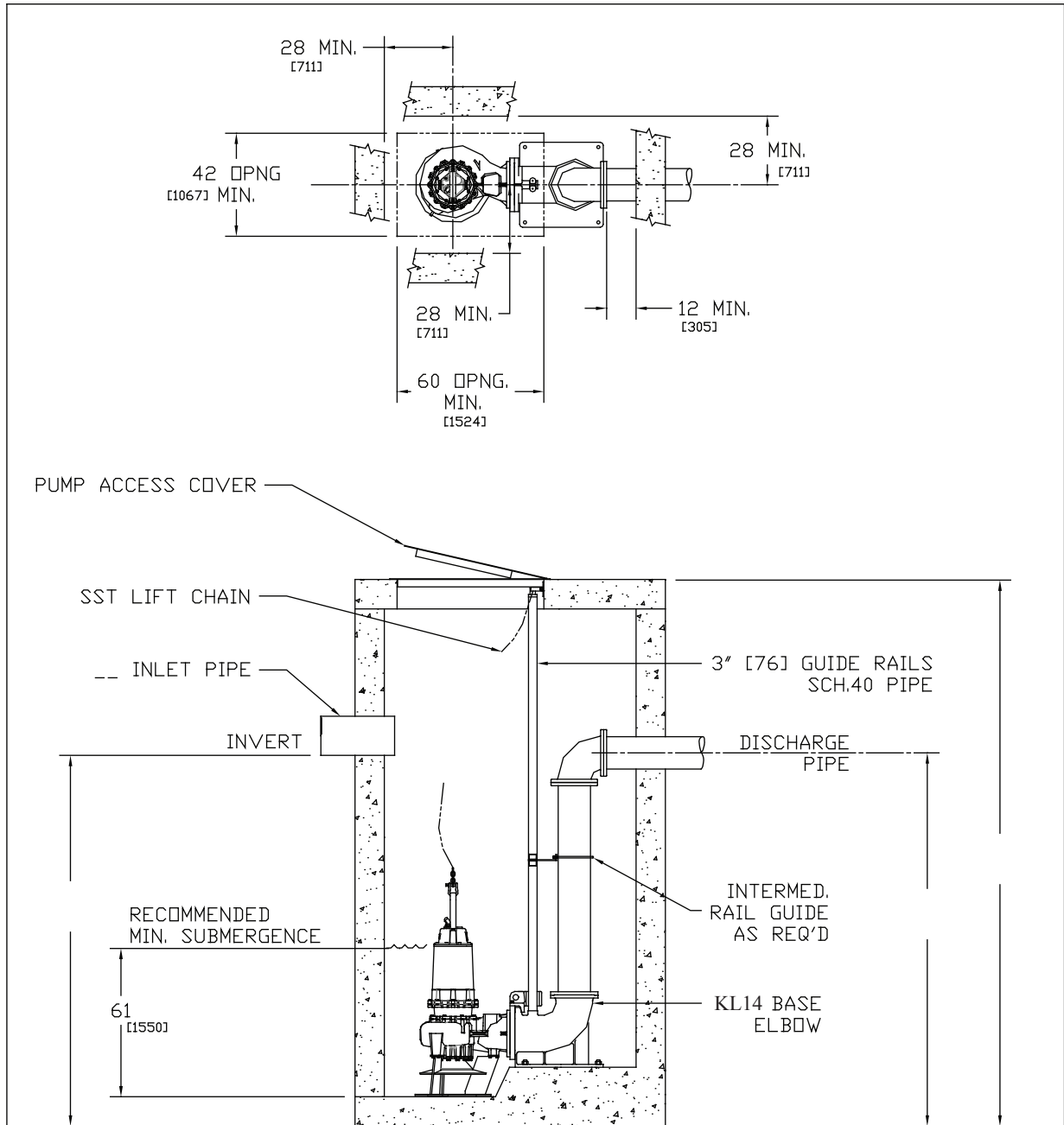

Notes:

1. All dimensions in inches and (millimeters).
2. Pump spacing per (HI) Hydraulic Institute standards.
3. Refer to pump dimension and liftout dimension sheets for more details.
4. Recommended minimum submergence levels noted.
5. Discharge base elbow must be placed above sump bottom as noted.
6. Dimensions may vary due to normal manufacturing tolerances.
7. If discharge pipe is larger than discharge elbow, eccentric reducer must be used limited to 2X larger maximum.

Pump Series

K14VK

14" SUBMERSIBLE SEWAGE PUMPS

DUPLEX INSTALLATION DIMENSIONAL DATA

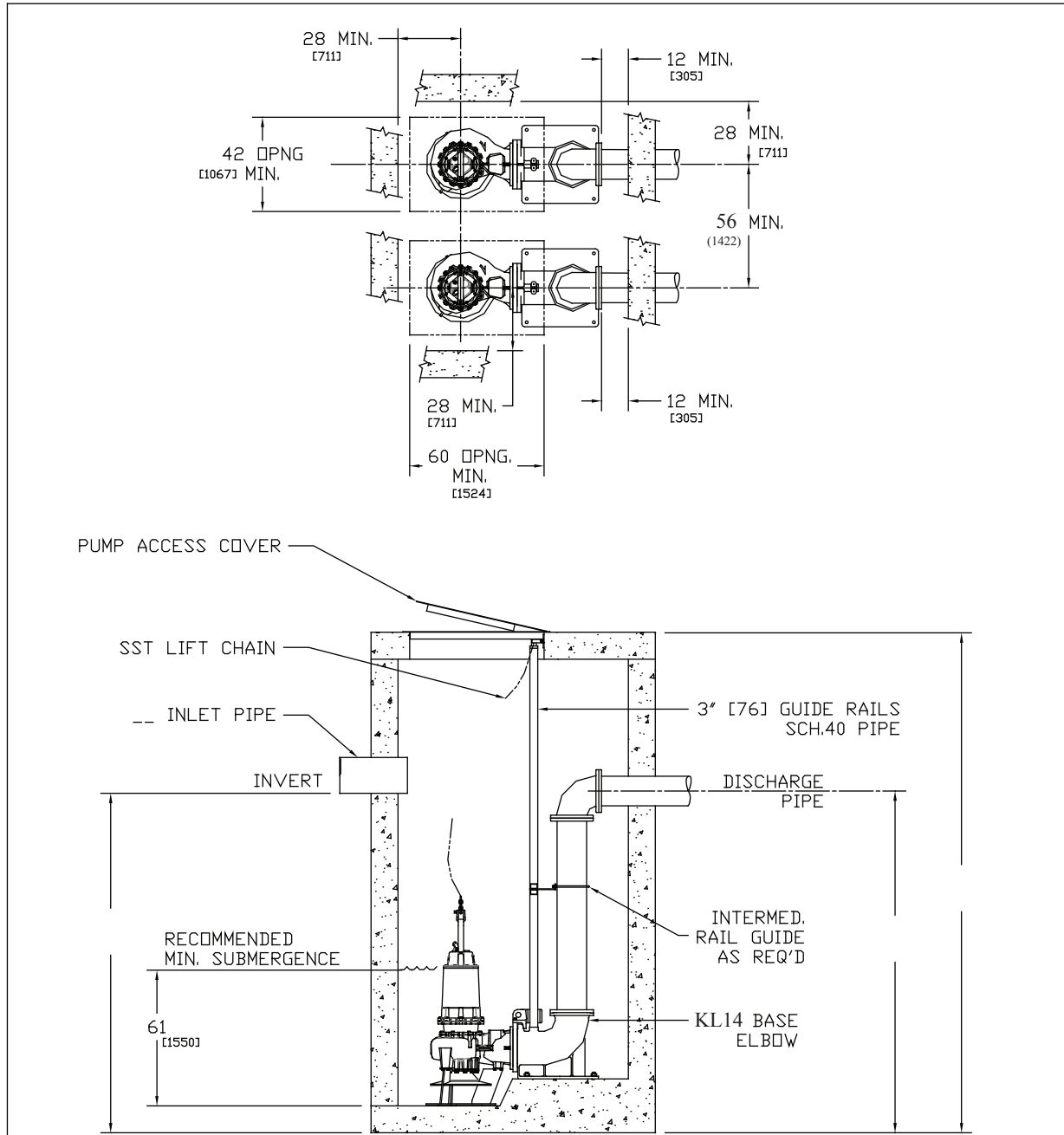

- Notes:
1. All dimensions in inches and (millimeters).
 2. Pump spacing per (HI) Hydraulic Institute standards.
 3. Refer to pump dimension and liftout dimension sheets for more details.
 4. Recommended minimum submergence levels noted.
 5. Discharge base elbow must be placed above sump bottom as noted.
 6. Dimensions may vary due to normal manufacturing tolerances.
 7. If discharge pipe is larger than discharge elbow, eccentric reducer must be used limited to 2X larger maximum.